

International Committee
Minutes of the meeting Feb 25 - 28 2020
Singapore
Venue : National University of Singapore, School of Computing

First Session, Tuesday Feb 25

Present:

Physically:

Sun Teck Tan	Singapore
Ben Burton	Australia (Chaired meeting)
Valentina Dagienė	Lithuania
Mile Jovanov	Macedonia
Eduard Kajiņičenko	Latvia
Eslam Wageed	Egypt
Yugo Isal	Indonesia
Ágnes Erdosne	Hungary
Eljakim Schrijvers	The Netherlands Non-voting (joined late morning due to delayed flights)
Margot Phillipps	New Zealand Non-voting

Virtually:

Greg Lee	Taiwan
Araz Yusubov	Azerbaijan

0. The presence in IC of Steven Halim, Singapore (IOI2020 GA Chairman) was approved and the proposed agenda was approved.

1. Apologies: All members participated, but those who were unable to travel apologised.

The IC are grateful to ADA University (Azerbaijan) for hosting three members of the ISC who could not attend in Singapore, and for covering all costs.

2. Confirmation of Minutes from IC, August 2019

Some changes are required in the section about the statistics website changes. There is a policy now on Drive. Ben asked that approval be delayed until the IC can see them (poor connectivity) as Eduard also needs to speak to Fredrik (yet to arrive in Singapore) to finalise that section.

3. Report by President – Greg Lee

- Greg apologised for not being present but he would have a 14 day quarantine if he went to any of Taiwan's advisory countries, which included Singapore. Greg thanked Ben for standing in as on site chair and stated he would try to join all the meetings on-line.
- Prof Sendov passed away in December and some have suggested something to recognise him at the IOI. He suggests a moment of silence at the first GA but is open to other ideas
- Encouragement of Girls: Switzerland has a European IOI for girls, so Greg is trying to get funding for Asian girls. Maybe there can be such competitions globally and then merge them with the IOI further down the track. There is no funding yet but if Greg can engage a corporate sponsor, he will inform us.

- Acer sponsorship: There has been no real progress as attempts to schedule a meeting with the CEO have not been successful. The director who attended IOI 2019 is positive about the IOI, but approval must come from the top. Greg suggested the production of a brochure which showcases the Acer involvement in the IOI the past 3 years plus the ISC survey statistics to support the value of Acer's involvement. Such a brochure could also be used to bring on other sponsors.

Ben suggested Araz be messaged to obtain relevant material from IOI 2019, which showcases Acer. Sun Teck said there would be a press release of the Acer presentation of a laptop to him earlier this morning and there will be another one at the end of the IOI when the 400 laptops will be given to less privileged local students. The Ministry of Education and Acer will have a joint press release

Greg said that as the distances are not great, possibly Singapore could invite the CEO to the 2020 IOI so he can see an event for himself, as we need to create an opportunity to meet with him. The question of funds was raised and Sun Teck said we can host him. Greg added Acer may well cover the costs if he comes.

- Meet a day early at an IOI: In 2019 we got through everything without needing extra meetings, so this is not urgent. If it is not necessary, then we can drop this item.

Discussion: There were alternative views voiced. The advantage is it allows IC members to spend more time with GA members. The disadvantages are the extra cost to the hosts and the need for some IC members to travel with their team as they are also team leaders. Ben suggested the IC consider this proposal case by case each year and to assess for 2020 whether the IC completes its business at this meeting.

4. Report by Secretary – Margot Phillipps

(a) New countries requests :

- After the requirements were sent there has been no further progress from Belize , Honduras , Qatar , Kosovo, Panama, Pakistan and Senegal..
- Albania: an email received Feb 25 was read to the IC. An NOI has not yet been held, although intent has been expressed. Mile added that they participated in previous Balkan Olympiads and gave some background. After some discussion, Eduard suggested that the regulations be changed to reflect practice. If a country lapses, they cannot be invited again as an official observer; either they need to pay the guest fee or apply to send a full National Delegation. Ben offered to draft a regulation change.
- The UAE: were paying observers last year. Steven added that he was invited to train a team this year but had to decline as he is over committed. Greg has made a request for a report after their NOI. If there is a response by mid June, which the IC approves, then they can be invited. Araz added that it is useful to copy the secretary into country requests to the host, as then there is a witness to the requests and the communications.
- Cambodia: Sun Teck said that their observation was that they are not yet ready but he hopes they will be able to have an NOI next year and Singapore is willing to help.
- Nepal: There have been a number of parties wishing to be recognised in the last year and the secretary has connected them. One is insistent it be invited to send a team this year, but no NOI has been held. Again, if there is a response by mid June, which the IC approves, then they can be invited to send an Observer. One of the parties also asked if a student in a gap year post high school is eligible and the response should be No.
- A general discussion about new countries was held. The conclusion was that it is good to have support from current local countries but such support shouldn't be an over-riding factor in an IC decision. Nor is it expected that an IC member be invited to oversee the applicants processes about the application.

- (b) A student from Finland, who will be 6 days too old to compete again, requested dispensation and quoted an IMO instance. After discussion about the problem of where would a line be drawn in terms of number of days, the IC rejected the application.

5. Procedural matter.

The ISC has had a change in personnel for the February meeting. Ali Bahjati has replaced Ali Sharifi, who is a bioinformatician helping with Covid-19 research in Iran. Ali Bahjati has not been elected and therefore will not vote.

(4. Report by Secretary continued)

- (c) There has been an Offsite request from Iran for 2021 as Iran does not have diplomatic relations with Egypt.

Eslam stated he was comfortable with Iran and Israel having an offsite IOI and suggested that letting the other countries know early where an offsite would be is helpful to them, and those 2 countries would need to be prepared to attend the same venue, possibly the UAE.

The regulations state that Offsite competitions are only if an IOI country does not have diplomatic relations with the host. This was intended as a rarely used option and that the IC should ensure from 2017 that any host country can invite all other IOI countries. Eslam was asked to get advice from his foreign ministry that it is still possible for visas to be granted to Iranian and Israeli teams.

Host Site Visits

Typically these are not recorded in IC minutes. However, as Greg and Araz were not able to be present, some maps of venues and notes summarising issues noted by the hosts are added as an addendum to these minutes. Some venues were not able to be visited as they were in use for quarantine or otherwise booked.

Second Session, Wednesday Feb 26

6. IOI 2020 Report - Singapore (Sun Teck)

- **Registration:** Will be opened as soon as this winter meeting is over by sending invitation letters to all known team leaders. There is a target of a “soft” close by Sun 14 June 2020, and travel information must be entered by Sun 28 June 2020. About 20 countries will need a visa so they should go to https://www.ica.gov.sg/visitor/visitor_entryvisa .

The major change in the registration is the requirement to give consent for medical treatment for students and guests 17 and under, although adults should also give consent. Sun Teck explained in response to questions that students cannot be forced to accept medical care, but if they want it, then the consent to share medical information will speed up any treatment at a public health facility and it must be consented to by the guardian/leader that the medical record will be scanned and uploaded. However local Covid regulations may require a sick student to be isolated and/or treated. Steven is working with Kim to amend the registration system.

Non binary gender registration was discussed. The passport identified gender can be used for registration, but reassigned if required for accommodation on arrival. Transgender students self-identify and should be assigned to a floor based on that. If

bathrooms/floors are a subject of discomfort for either the student in question or others on their floor, then a separate neutral bathroom could be assigned.

- **Guest fee:** Euro 1500, to be paid in Singapore dollars by credit card or bank transfer with expenses borne by the payee.
Sun Teck said, after some discussion that the capacity for guest numbers is limited at Kent Vale and on the excursions. Alternatives for limiting numbers were discussed. The role of adjunct was discussed, as was the arrangement for future hosts bringing one extra technical person for no cost. The case of guests who wish to follow the leaders program rather than the guest track was discussed.
Steven said he wants a transparent separation. Guests will not be allowed in GAs or to help on translation nights, whereas adjuncts can. Similarly adjuncts cannot go on guests excursions.
Kim said that the registration system can be altered but expect mistakes to be made as its the first year this will exist. Ben added that people who mis-register can ask the GA chair for permission to attend GAs if necessary.
- **Early Arrivals:** Either at the leaders' accommodation (\$81 per night) or Kent Vale for a family for \$152 - \$255 per night based on the number of bedrooms (1 to 3).
- **Arrival/Departure points:** On arrival on July 19th, teams will not wait but travel to NUS in a Grab Taxi. The car will accommodate a normal team but if there are guests, Singapore will organise 2 cars and pay the extra. The team guide will be at the airport and organise the Grab car(s). At University Town, there will be a luggage point, in-site registration, a Bento box meal and then leaders and students are taken to their respective accommodation.

For departures, there will be several bus trips early in the morning of the 26th to Changi airport regardless of the actual departure time. There can be no late departures (latest will be midday on Departure day) as NUS will need the rooms for the start of the new semester. There will be room at the Multi Purpose Hall to store luggage if a team, for example, wants to go to a mall. Grab will not be available for departures.

- **Misplaced/delayed luggage:** Use the normal procedure at the airport, obtain an acknowledgement slip. The Address for delivery is IOI Secretariat, RC4, UTown (to be confirmed). Teams should submit the acknowledgement slip and contact information to the IOI secretariat and collect from the IOI secretariat when luggage arrives.
- **Transfer between venues ;** Hired mini-buses will run at regular intervals and there are NUS Internal shuttle buses. (NUS NextBus App in Google Play). Most venues are within 5 to 10 minutes walk under covered walkways. The hired mini buses will run on translation nights.
- **Excursion Day 1: 22nd July (Marina Bay area):** Leaders are to be with the contestants, assigned to designated buses. Seating will be randomised so that you meet new people. The guides are high school students, which is the rationale for having the leaders with their students. Assemble at RC4 before departure for Merlion park, MBS Skypark, Garden by the Bay, Marina Barrage and a Walking tour. Lunch vouchers will be provided to purchase food from local vendors.
- **Excursion Day 2: 24th July (Universal Studio Singapore (USS) and Haw Par Villa)** Leaders are to be with the contestants and assemble at RC4 before departure, to arrive by park opening time (~10am). Lunch vouchers to purchase food from local vendors

inside USS will be provided. Leave USS by 5pm (staggered, last bus by 6pm), transfer to Haw Par Villa. Dinner at Haw Par Villa. Leave Haw Par Villa at 9pm.

- **Excursions for Guest track:** Beside joining the main programme for some activities, a special social programme is designed for the participants in the Guest track. Due to the procurement regulations at NUS, no extra payment is allowed for the event. Hence only Guest track participants are allowed to join the excursions. Any other participants who wish to join the guest track excursion will need to pay for their own entrance tickets to the attractions and for their meals, subject to the availability of seats in the tour coach.
- **Internet access outside quarantine times:** A Local SIM card with data will be provided and there is NUS wifi. For Quarantine: Communication devices will be collected and kept with the team guide during quarantine and returned after the contest. The guides will act as alarms.
- **Translation computers:** Spare Notebooks will be provided when needed. Eduard: commented that there needs to be both 5 and 2.4Ghz wifi available as many laptops didn't support 5GHz
- **Meal arrangements:** Breakfast will be at various accommodation dining rooms. Lunch will be at MPSH6 for students and MPSH1 for Leaders/committee members. There will be cash vouchers during excursions. Dinner: On Opening and closing ceremony days, dinner will be at UCC, at Haw Par Villa on 24th Evening and on the other days, the Dining hall at RC4 for students and MPSH1 for leaders/committee members
- **Nomination of GA Chair for IOI-2020:** Dr. Steven Halim as he is familiar with the GA meeting procedure and familiar with most of the IOI people. Kim expressed concern that Steven may be stretched to perform this role as well, but it was agreed that others can chair if required in an emergency.
- **Extra Activities:** Acer Knowledge Fair on 21st July, after the first contest day. There may be other sponsors' activities and a Sponsors' Fair on 23rd July and also Booths and a talk for students on the Leaders Social Night after GA6. Special water will be provided, sponsored by Jump Trading after GA6 for leaders. There will also be a Micron Factory (semiconductor producers) visit on 25th July, the morning before the closing ceremony. This will be only for contestants and team guides, and lunch will be provided by Micron.
- **Covid-19 effects - postpone/some students quarantined or off-site/?:** Update of the COVID-19 situation in Singapore and the world. The problems we are facing now include uncertainty: vendors refusing to accept our orders (eg: 500 tables) that they might not be able to fulfill or we may cancel. The options include Downsize, postpone, or suspend (cancel). A survey advised not to postpone but it isn't easy to find a suitable other time with suitable venues. There could be a distributed contest in many rooms, with no ceremonies. Off-site should be considered. The Ministry has promised they will cover any extra costs due to the virus.
There are a number of scenarios, but with so many unknowns it isn't necessarily useful to discuss at this time. It may be possible to quarantine up to 20 countries. It is important to tell people not to buy airline tickets yet. It will be useful to meet online in late April or early May 2-7pm local time.

Other discussion included looking at if another country nearby could host countries that can't come to Singapore. This was considered not to be a good look. Ben said we should not consider such off-site hosts as the Scientific and Technical committees will be too stretched.

It was then agreed to let Sun Teck organise an online meeting late March.

7. IOI 2021 Report - Egypt (Eslam)

Transferring to Arab Academy for Science and Technology Main Campus. 6 hotels were presented with their capacities for housing guests, leaders, students, volunteers. There will be hotel separation by gender for contestants and volunteers. The capacities for dining, the GA, and the square metres for the contest hall (an airconditioned outside tent) and Translation Rooms were shown to be more than sufficient. Excursion 1 will be to Montaza Beach or Porto Marina North Coast and Excursion 2 will be to New Egyptian Museum, Pyramids and Lunch. The guest program is yet to be arranged.

Eduard asked that as the closing ceremony is outdoors will it be late in the day. Eslam responded it will need to be as otherwise it is too hot.

8. IOI 2022 Report - Indonesia (Yugo)

The General Directors and Directors of Education and Culture have not yet been determined post elections. The Universitas Indonesia venue is now no longer an option. The next (preferred by the Ministry) is to hold it in Central Java (Magelang or Jogjakarta). A taskforce to prepare an IOI has been established with past IOI contestants and Ministry representatives (Education, Tourism, Foreign Affairs) as well as sponsors. A National Achievement Centre has been established with oversight for an on-site APIO in 2020. No finances have yet been committed.

9. IOI 2023 Report - Hungary (Agnes)

A Consortium has been formed between three parties: Digital Success Nonprofit Ltd., John von Neumann Computer Society and The University of Szeged, ELI-ALPS Science Park

As a model event, they are running CEOI June 29 to July 6 2020, building teams for the Host Scientific and Technical Committees. Agnes said she hope that the core team will stay the next 3 years.

The detailed budget is awaiting approval by the Ministry of Finance.

9. HONORABLE MENTIONS (HMs)

Eduard suggested there are 2 ways - everyone who didn't get a medal but got 100% on a problem (like the IMO) or the top 10% without a medal (like the IB). He had discussed this with some of the ISC and they don't see a problem (e.g., with the ISC being pressured to select a task of suitable difficulty). The numbers based on the previous years would have been 47 (2018) and 36 (2019)

Mile had done a detailed analysis using the Mathematics, Chemistry and Physics Olympiads as models over the last 5 years. It had also been used with the Balkan Olympiad in Informatics. He proposed: About 20% additional participants will receive Honorable Mention acknowledgement.

The regulations E6.11 for bronze medal allocations should be changed to :

The score necessary to achieve a bronze medal is the smallest score such that at most one half of all contestants receive a medal.

The score necessary to achieve a Honorable Mention is the largest score such that at least 70% of all contestants receive an acknowledgement (medal or Honorable mention).

As a result only a few countries would go with no medals or HMs. (or a half of those who currently leave an IOI with no medal). This also reflects the demand from community in discussion group

Three votes were taken: the Model of 100% score for an HM (2 in favour), at least half the bronze cut off score (0 in favour), 70% (additional 20% get HM) (8 in favour)

Eduard: raised that getting 100% on one task may change a student's strategy. And 70% devalues HM, so why not combine. HM for that 20% AND those who get 100 for a problem.

(Lunch occurred here and Greg and Araz were not present for part of the meeting)

Eduard then withdrew his proposal .

An approval vote was taken on 4 options : Do nothing (0), Based on a percentage ranking (7), Fully solve a problem (2) , Combination of 2nd and 3rd options (6)

After more discussion it was agreed that Ben would draft a regulation change to incorporate Honorable Mentions ("at least 20%" and no change to the bronze medal allocation regulation) and there would be no mention of HMs in the closing ceremony.

10. Distinguished Service Awards

Eduard nominated a recipient for 2020 and spoke to their nomination but abstained from the otherwise unanimous vote. The recipient has accepted, but their name is redacted here (as of September 2020) since due to COVID-19 the award will not be publicly announced until IOI 2021.

A second nomination was received and discussed at length. Some details in the nomination were not consistent with other IC members' recollections and were checked with the other committees. A vote (6 to 4) declined the nomination.

11. Long Service Recognition (Eduard)

At the 2019 final GA, Greg mentioned a number of people who had served 25 or more years. The data are available on the Statistics website, so it was raised whether we should issue certificates, possibly for 15, 20, 25 years. Ben thought they shouldn't be presented but put in pigeonholes, and would like them not to be an incentive for leaders to stay on when they would otherwise retire. Eduard asked if it was a burden for the host.

An approval vote was held for : No certificate (1), Pigeonholes (6), Presented in the GA (6)

During a break Eduard compiled statistics, including if the person had been a contestant. Mile said that shouldn't be included as it was a different type of service. The numbers suggested several options for the number of years at which certificates should be issued, but it was agreed not to issue them retrospectively for people no longer attending, unless by request.

An approval vote was held for the number of years: At 5, 15 and 25 years (2) and at 7, 15 and 25 years (7)

It was agreed that 7 year certificates should be in pigeonholes. A decision about the mode of delivery for 15 and 25 year certificates was deferred.

12. Funded Projects (Mile)

The proposal for the detailed analysis of the 2018 tasks project was revised down from 4000 to 1000 Euros, which Tomasz Idziaszek is happy to receive on completion.

New Project Proposals:

1. Bojan Kostadinov (currently handles IOI website), proposes an "IOI weekend" to keep the community active outside of an IOI period. It would include book authors, highlights from previous IOIs, what individuals are doing now, how to start competitive programming, how to move from competitive programming to the workforce, gather feedback from past participants via Q and A etc. The project would be created in 3 months with high quality video and a website.
2. Jamal Hasanov proposed an IOI contestant data analysis project, split into 3 sub-projects - Real time and post-contest statistics and insights, Request Fulfillment, and Submissions and Code analysis. The deliverables are 2 high quality journal papers (one being the Olympiad in Informatics) and software that visualizes the statistics during the contest (A real-time pattern analysis and prediction program). 6 people would be involved.
3. Also received was a proposal for a workshop to gather 10-20 representatives from different IOI countries that are involved in the training of the potential IOI participants for many years. All of them will present their experience, and the national system of training (training camp, online training, year-long contests etc.).

Araz commented that a lot of the CMS is open source and he would like to hear from the ITC and this year's HTC on their view on the 2nd proposal. Eslam commented that similarly Kim produces the video content for the IOI for free. Eduard thought that as projects 1 and 3 are from the same country, they could be combined. He also added that rather than release all videos in one weekend, they would be better drip-fed over multiple weekends.

Voting:

Proposal one: 8 for, 1 abstention. To deliver over a single weekend: 0 for. To deliver over multiple weekends 7 for, 2 abstentions. Mile agreed to talk to the proposer, to tell them it is approved but is to be delivered over multiple weekends. The approved budget is 5000 Euros.

Proposal 3: 0 for.

Proposal 2: A decision was deferred until the joint meeting with the Scientific and Technical Committees.

On day 3 Eduard reported that the ITC feedback was that they do not think this would be very useful for ITC and HTC. Part 1 would be much better if it were added as a feature to CMS, instead of as a separate tool. Similarly, part 2 would be better as part of whatever ticketing system HTC will use this year, as such work should absolutely be done together with this year's HTC, not a separate group, to be truly useful. Part 3 is not that useful for ITC and HTC. Although we agree that this would most likely give us some very interesting articles.

A decision was deferred until the joint meeting.

13. Country/Regions (Eduard)

Emails have been received questioning the status of Hong Kong and Macau as countries on the website. The websites and registration system are not consistent. The proposal is to have one way to refer to the entities. Kim and Ben suggested "delegations" but Mile said a delegation cannot be a member of the IOI as the regulations use "country" and define the term. Greg said that we should respect the country's wish as to what it is called.

Eduard confirmed he would use “Country/Region” as the heading for the Statistics website, and for individual country names, we would consider requests from delegations as to what they are called.

14. Trophies

Steven asked if the 2 remaining of the old version should be used in 2020. Ben proposed one is given for the DSA and if there is only one winner, use the 2nd. Otherwise, 2+ of the new should be used.

Eslam pointed out that only the plate needs to be changed every year on the new one (the prototype was shown, and he would like a small design feature to be altered). He also said they may be more expensive than the old design. Greg offered to get a price from Taiwanese suppliers if he could be sent a prototype.

The new logo, in svg, ai and png format have been given to the secretary to store on Drive. The new logo was approved unanimously and Ben thanked Eslam for his work.

15. 2019 Survey and Singapore’s responses (Sun Teck)

Acer has been asked for 8Gb RAM, machines rather than 4. It's not easy to address screen or keyboard comments. The security in Baku felt inhibitive and will not be so in Singapore. There was no wifi on the first day and Singapore will have it available. Singapore plans that any excursions by bus will be punctual. Food that may cause allergic reactions (eg: peanuts) will be clearly labelled. There was some food poisoning, but regulations in Singapore require the time at which food should be removed is displayed. For excursions, leaders will be with students.

Ben thanked Sun Teck and suggested all future hosts also take note of survey results.

16. IOI 2019 Final Report (Araz)

A full report, following the 2018 final report format was sent to the IC. The report was marked confidential because of the financial information in it. It also detailed the attendance, the problems, the scores, the program, photos for each day, the venue plans, the daily organisation details for the 3 streams (students, leaders, guests) , the contest rules, the conference and GA agendas, Volunteer organisation and security and safety measures.

The major highlights of the report were:

- Strong government support, although this wasn't clear until May.
- The support by Acer. The equipment left has been used and Acer was informed.
- The Caspian Event Organisers - local event management partner
- Communications
- Committee structures – sub-teams of Venues and Ceremonies, Accommodation and Food, Transport and logistics etc.

The Azerbaijan HSC relied on the help of the IOI community, especially Iran and Russia. The Azerbaijan HTC committee performed well, based on the ITC feedback and in the spirit of IOI, there was a great exchange of experience. The national OI was in the IOI format for experience. Azerbaijan had a more traditional computer architecture compared to Japan.

There were 498 participants, 148 volunteers plus committees and 78 guests.

Communication: Facebook had 2,382 likes, You Tube had 506 new subscribers with 38,343 views, and almost 2,500 emails. Araz has some templates for email which he can share

Novelties: A cookbook with Knuths' foreword, postage stamp, cultural night, a special bag for the IOI flag and guest rooms. There was a fee for single rooms but it was cheaper if the guest accompanied another leader or guest.

Araz thanked Japan for the report format. If the financial part is removed, it may be used by future hosts.

Ben thanked Araz for the report.

Third Session, Thursday Feb 27

Item 2 was revisited. Confirm minutes: approved – for 9, against 0, no abstentions (Araz not present)

17. Budget (Kim)

This is an intermediate update. The invoice for the journal has recently been received and approved. The ISC has claimed because of Covid 19, and if they go over budget he suggests they make a request for IC to approve.

18. Journal (Valentina)

Twenty proposals have been received. Three full papers have been received of which two have been reviewed. The deadline for the rest of the full papers is the end of March.

All the papers in all journal editions are now in Scopus Proceedings. Last year Valentina applied to the Web of Science proceedings, which is prestigious, but they didn't accept the application or give reasons, so she will apply again.

Steven and Sun Teck would like a local keynote speaker for IOI 2020.

Sun Teck said the Ministry of Education will open the conference to local teachers and 2 teachers have submitted papers. A second auditorium can be opened and web-cast for local teachers. It may need to be a video conference so that they can ask questions. Valentina reminded Sun Teck to prepare certificates for presenters in advance.

Item 4C was revisited.

The experience of 2017 and why countries were accepted or declined an off-site option was discussed. The regulations state that if an invitation can be granted, deliberately not inviting is not permitted. Eslam requires 4 months to determine the status of the countries within Egypt who are requesting an off-site competition.

An approval vote was taken : Accept (0), Decline (3), Wait until July to make a decision (8)

Steven added that due to Covid 19 , some countries would not currently be able to be invited. However as the situation is constantly evolving, a reasonable conclusion cannot be reached now.

19. Equity and Diversity (Ben)

We ask hosts to put the code of conduct in the bags (a physical copy so students are aware) and we ask HSC to make sure it's in the rules. We gave harassment guidance for team leaders and how to handle it when they see it. Ben would like to see it in pigeonholes again but asked Eslam if that was possible in 2021. Eslam replied it could be sent electronically by the IC to leaders, but the region has laws against, for example, rainbow ribbons. Ben said that with the

possibility of Ministers in the GA room, it may not be possible to even discuss harassment. As there will be LGBTIQ people at the IOI, we need to discuss it now to ensure they are safe.

Eslam said that it is permissible to believe anything about, for example, rainbows and guns but it is not permitted to spread these ideas. Ben asked that the analogies be kept appropriate. The code of conduct may need to be sent to leaders and they will be asked to ensure their students are made aware (or given copies). So the GA should be informed this year.

Sun Teck added that local laws and the repercussions of violations (re smoking, spitting, throwing rubbish, drinking on the subway and bringing in drugs) will be made clear on the website.

Eslam expressed concern that a discussion within this year's GA may cause problems as there may be people who wish to cause trouble.

20. Regulations (Ben)

Ben sent through a document showing all changes. The effects were to make actual practice and the regulations consistent (eg: "Competition Procedures" and "Judging procedures" were replaced with "Contest Rules", and how appeals are conducted), to build in Honorable Mentions, and other fixes were made, such as when there are fewer nominations than positions vacant on committees, and that leaders should be available during the whole contest for translations. The detailed changes are recorded as a second addendum to these minutes.

There was discussion about how to handle people only wanting a one year position on a committee when there are one and three year positions. A person can step down after one year.

There was also discussion about the power that a host has to ensure its local culture is reflected in problem statements. The regulations are clear that the ISC should make the final decision and have the final responsibility. Any impasse between ISC and HSC can be put to the GA to make a decision, but it should be noted that generally the host and international committees work very well together.

Long Service Certificates are not in the regulations and Mile would like that this may be reconsidered in the future. As Notes do not require GA approval, certificates could be added as notes. The secretary was asked to add Long Service Certificates to each agenda.

The wording for Honorable Mentions was discussed but it was agreed that the proposed wording captured the intent correctly.

Bids to host should be connected to the community via the usual national delegation. Capturing that in a new regulation A4.1.2 was discussed but not agreed upon. The President and Secretary should ask any bidders not known to the community to connect with the usual country representatives.

The removal of N5.6.2 was promised to the GA to be deleted this year.

S5.10: The 3rd and 4th bullet points don't stop the IOI publishing results but the Hosts are obliged to post results and all contestants. The Statistics website function is not recognised in the regulations, but can sit in the office of the Secretary. Eduard stated hosts must provide a list of who actually attended.

Using experimental regulations to introduce Honorable Mentions this year versus get them approved this year for implementing in 2021 was discussed. The GA needs to be given a month's notice. A vote was taken to introduce it in 2020 under an experimental rule change and was passed unanimously.

The entirety of the changes were approved. (9 for, one abstention)

Item 11 Revisited - The Distribution of LONG SERVICE Awards

Mile stated that we decided certificates recognising 7 years service would be delivered via pigeon holes and he proposed that certificates for 15 years be awarded at a GA meeting and those for 25 years should be at an opening or closing ceremony.

Eduard said that by presenting at a ceremony, the students see the service of their leaders. It doesn't have to be time consuming as everyone awarded could have their name called, all stand, be applauded together and sit. And as it's just a piece of paper, it won't cause people to stay on longer than they really should. Agnes, Valentina, Araz and Sun Teck agreed. Eslam preferred that they would go on to the stage and receive a framed certificate.

Mile said 2020 will be a special year as there will be 7,7+,15,15+,25,25+ years so time is more critical for this year. But we could decide on a different protocol for the following years. Greg thought 15 to 24 years should be acknowledged in the GA and 25(+) at the Closing ceremony. Kim expressed that the closing ceremony should be for the students.

A vote was taken for the presentation of 15 year certificates : In the pigeonholes(1), in the GA(8), Standing at the closing ceremony(4), on the stage in the closing ceremony (3)

A vote was taken for the presentation of 25 year certificates : In the pigeonholes(0), in the GA(2), Standing at the closing ceremony(5), on the stage in the closing ceremony (8)

There were no objections to the 7 to 10 people coming to the stage as a single group, However this will alter the program for the closing ceremony in Singapore and they will need to consult with the Ministry. It was agreed that Singapore could make the final decision whether it was on the stage. Margot suggested that it be kept distanced in time within the program from the DSA award. There was some further debate as to whether attending as a guest should count, with no resolution.

21. Any Other Business

Mile wants previous websites and scores to be archived. This could be discussed at the joint Ic-ISC-ITC meeting.

Eduard suggested that the proposal for the IC to meet a day early was an extra burden for the host and could be negated if we had an online meeting earlier. Eslam though it should be taken case by case.

22. JOINT Meeting: ISC, HSC, ITC, HTC (including Greg and Araz offsite)

ISC Report (Jakub Łacki)

The HSC received 15 tasks and the ISC a further 2. Four were considered inappropriate as they were too similar to past tasks. Of the remaining 13, nine have been selected at the meeting and they form a nice problem set.

There was a report from the previous HSC and there is the usual plan to write documents for future hosts, so that knowledge is transferred by documents rather than relying on people in common.

Mile asked what time will the tasks be finalised in terms of text? Jakub checked that he was referring to Translation night, and then responded that there is a plan for the ISC to see the tasks earlier, and so significant work will be done before the IOI, with the hope that major changes will not be required on translation night. There is also an intention to ask for only crucial minor objections. He also added that the HSC is keen to collaborate early.

ITC Report (Fredrik Niemelä)

The committee has reviewed the plans for the contest hall and the technical specifications, as well as for the Translation process and the incident management so that responses will be consistent, fast and predictable.

The problem with translation delays on day 1 in 2019 was discussed and Jakub added that the issue was that there were not enough people, and as volunteers left, things got worse. Farid agreed and said the biggest problem was related to accepting late changes.

As soon as a country has finalised that the translations are done and it is confirmed happy, the tasks will be printed as one chunk per contestant. There will be 5 volunteers, in parallel, who will print and envelope the tasks and once its completed, they will notify the leader to come and verify.

Mile questioned the need for verification. Fredrik said that the plan is to optimise for those that finish later, not for those that may finish earlier, and mistakes do happen. The plan is to save time for the latest finishers, not the earliest. Kim asked if verification is required for tasks in English and Fredrik said not. Others added they know mistakes in enveloping have happened in the past so verification is required. Mile said verification is a bottleneck and a second volunteer could check. If there was a mistake, the student can ask and while waiting, they can read the translation online. There was further discussion whether verification can be optional and votes were taken on options.

The final vote was in favour that everyone must verify. (10) (6 for it being optional)

There was a discussion about whether time limits/deadlines could be set on when tasks should be finalised for translation purposes. Different members gave their experiences of their process. Jakub said the deadline is the start of the contest and it's not possible to ignore something a leader may bring up that's important. Fredrik and Ben thought the ISC should not accept late minor changes which may lead to very minor improvements, but which overall are not worth slowing the translation process down for.

Jakub said if a deadline is adopted for 2020. then it should be generous this first time (eg: 6 hours) with an intention to decrease it each year. The GA may push back if it is considered too

short and we should be cautious. Eduard stated that it will need to be made clear that the deadline is for finalising the version for the tasks, not for verification.

Ben raised a third issue relating to the translation process, how to make leaders translate. Jakub said there is an incentive to do a good job as the translation will go on a web page with the leader's name(s). Eduard added that leaders can change the story, which is disrespectful to the host, and it may be able to be enforced by running a translation through Google Translate.

Fredrik said that the ITC is looking at some paid machine translation API, so that may give a reasonable starting point for better quality translations. He added it is feasible to translate it backwards to check for faithfulness to the task.

Jamal added that we don't know if the students are satisfied with the quality of the translations received so it was suggested this be added to the survey.

Sun Teck had informed the IC (Item 15) of the ways Singapore will address some of the issues from the 2019 survey and so repeated this for the ISC and ITC.

Mile raised the issue of archiving past host's websites. Although the last few years have been saved, it would be good to have a goal of saving all previous sites. He asked if the ITC would be able to do that within a year or two. Jakub responded that there is a technical challenge of migrating it from the server and that it would be best if there was only one server. Eduard responded that hosts do not wish to use the current IOI servers. Past hosts will not continue to pay for the domain name. He will discuss with Azerbaijan if it is possible to get at least a static version and with Singapore to see if it's easy to move a version of 2020. 2021 can be moved to a subdomain of IOI.

The IC sought the opinion of ISC/ITC on proposal 2 (IOI contestant data analysis: Real time and post-contest statistics and insights, Request Fulfillment, and Submissions and Code analysis) . Fredrik stated that the basic statistics are covered well in the CMS. The second part should be built as part of the ticketing system, so there is better timestamping. Generally the ITC doesn't see the value in the proposal. Eduard suggested that the value is perhaps more for an HTC. Fredrik said HTC and ITC were in agreement. Mile suggested that the budget be reduced to 1000 Euros and see if they accept it. There were no objections to Mile offering this.

23. [More] Any Other Business [IC Only - The other committees left]

1. A general discussion was then held about food (spicy/halal options). All food will be halal.
2. Greg mentioned that his contact in Acer may be out of the loop as he didn't know the machine specifications. Sun Teck has already informed his local Acer contact.
3. The introduction of Honorable Mentions by use of Experimental Regulation (S7.4) was raised by Eduard. The IC approved (9 agreed., 1 abstention) the general principle to ask the GA to ratify the experimental regulation. Ben added to S7.4 and after some discussion including the history of the regulation, the final version of the proposed change was agreed.

“Regulations or changes may be implemented more quickly, without the full procedure of S7.3, provided there is IC approval. The GA requires at least one month's notification. The GA must ratify these changes in the first GA meeting of IOI'n, and if ratified then the changes become binding immediately after this vote.”

(6 agreed, 3 abstentions) . Ben will make an announcement about Honorable Mentions to the community at least a month before IOI 2020.

4. Eslam suggested an auto-reply on the official facebook pages. Steven said that for Singapore it was set to @io.sg and so someone will respond.
5. Eslam also offered to word the Long Service certificates and to bring a frame.
6. Greg asked if any IC members had heard from any potential future hosts. Eslam said Saudi Arabia is hosting the Physics Olympiad in 2024 so it is possible they may consider Informatics. Mile said Greece may apply for 2024. The possibility of raising the registration fee to make it more likely a host would offer if there was some financial support was discussed. Eslam offered to lead a discussion with the GA at IOI 2020. Margot is to send a future host request.

Sun Teck thanked everyone for coming and asked for attendees to complete a survey. Ben thanked Singapore and all their team and closed the meeting at 4pm.

ADDENDUM 1

Site Visit Findings:

MPSH1

- Can make translation procedure as electronic as possible. Don't print solutions, don't print initial tasks, make them available electronically. Mile suggested leaders could do a final acknowledgement electronically instead of being physically present when the envelopes are sealed.
 - HTC: Happy to implement. More importantly, need to discuss with IC/ISC to see if they're OK. Potential issues:
 - No paper initial tasks - can't read tasks as people are eating (unless they eat with their laptops)
 - Electronic acknowledgement instead of physical signing - leaders must acknowledge the **risk** that printout is erroneous.
 - Martin: I experienced too many issues with printing texts in non-Latin scripts to believe that this is an acceptable risk. If we are going to provide printed task statements to the contestant (which I do not assume to be necessary, but the GA probably does), they should be approved by the leader. (Well, there are technical solutions to that like rendering everything to a high-resolution bitmap, let the leaders approve the bitmap and print it later. But this is probably an overkill.)
- Regarding MPSH1, consider the potential amount of noise during the setting and packing up of F&B during the translation session. Might consider putting a divider?
- Regarding MPSH1, consider the sound 'degradation' of using such a large room. Please test the audio system.
- Possibly swap translation night from MPSH1 to MPSH6
 - Host rationale: MPSH6 is not in very good shape. Putting screens and stage will block fans and air-conditioning since they are wall-mounted.

- To check with ISC whether they are okay with the arrangement to use MPSH1 while the contest is ongoing. Do note that contestants might be walking *right outside* to visit the bathrooms. This also applies to the appeal sessions.
 - Possibly investigate whether they prefer an alternative room in another building.
 - Possibly consider allocating space in MPSH4 for the ISC.
- After teardown of MPSH1, move pigeon hole to outside aud 1?

MPSH2

- Host presented a known problem of noise from the neighbouring highway road.
 - Agree to provide earplugs to all contestants. Disposable ones, one pair for day 1 and another for day 2.
 - Air con may make it cold so contestants should bring a sweatshirt

Toilets

- Level 2.5: Convert both female toilets to male toilets. Remove gender sign, sanitary bin. → 4 male toilets.
- Level 1.5: Remain as 2 male and 2 female toilets.
- Level 1: Remain as 10 male and 10 female toilets. One gender neutral (handicap) toilet.
- It takes an extra 1 min for contestants that are assigned to level 1 toilets, as opposed to level 1.5 and 2.5.
 - Is this acceptable? (To ICs)
 - (Ranald) Yes, if we prioritize asking students to go to toilets in level 2.5 and 1.5 over level 1.

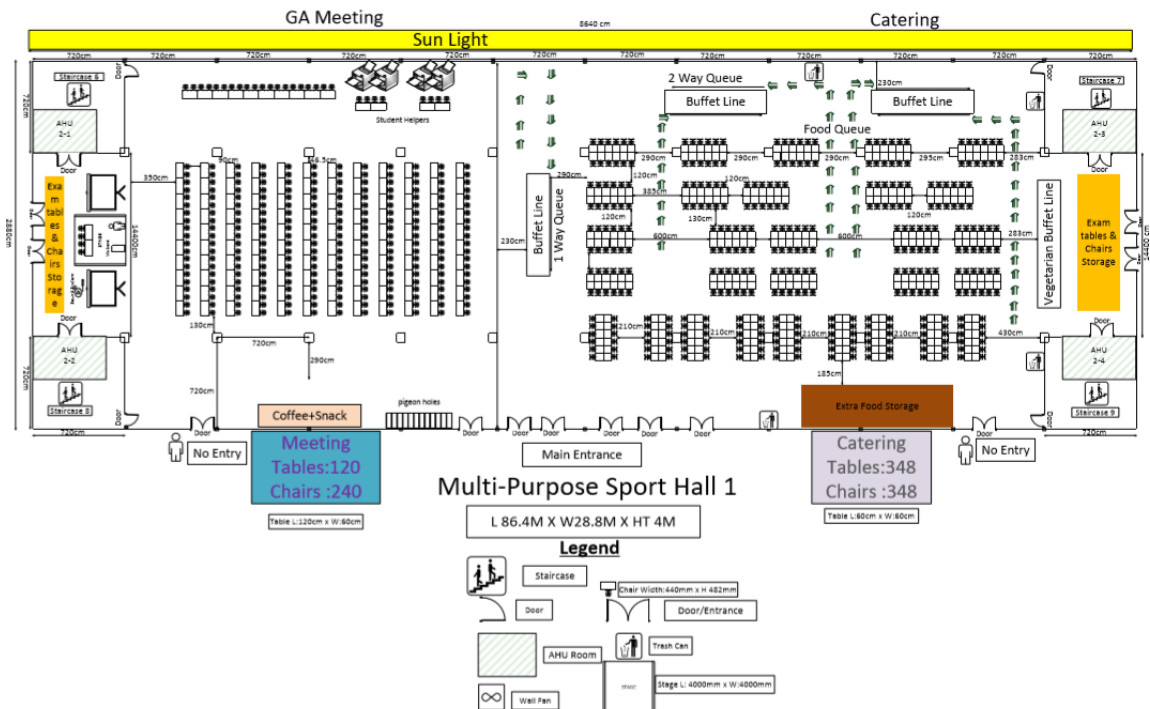

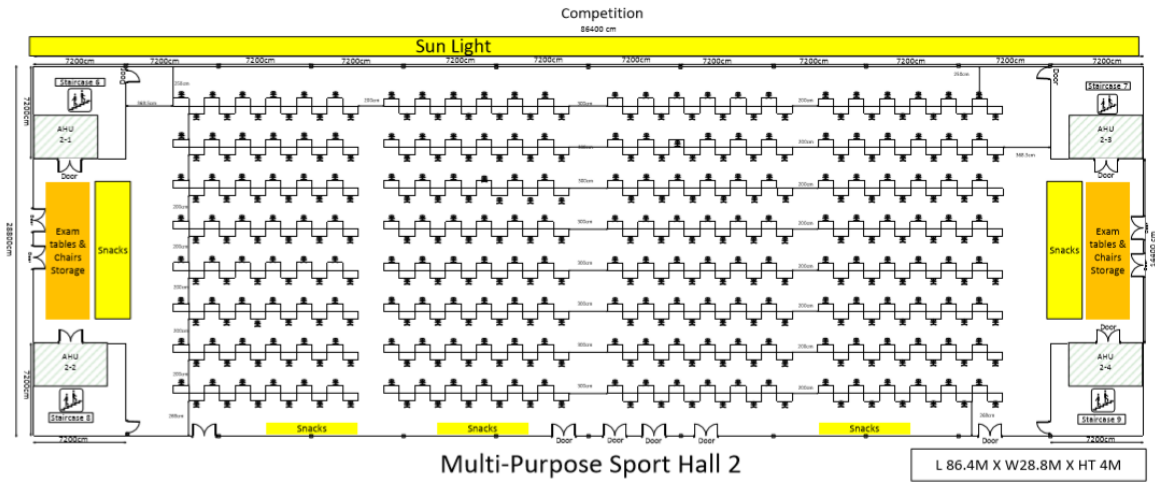

Total Tables & Chairs :384

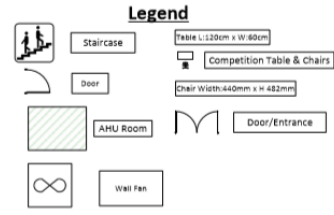

Catering

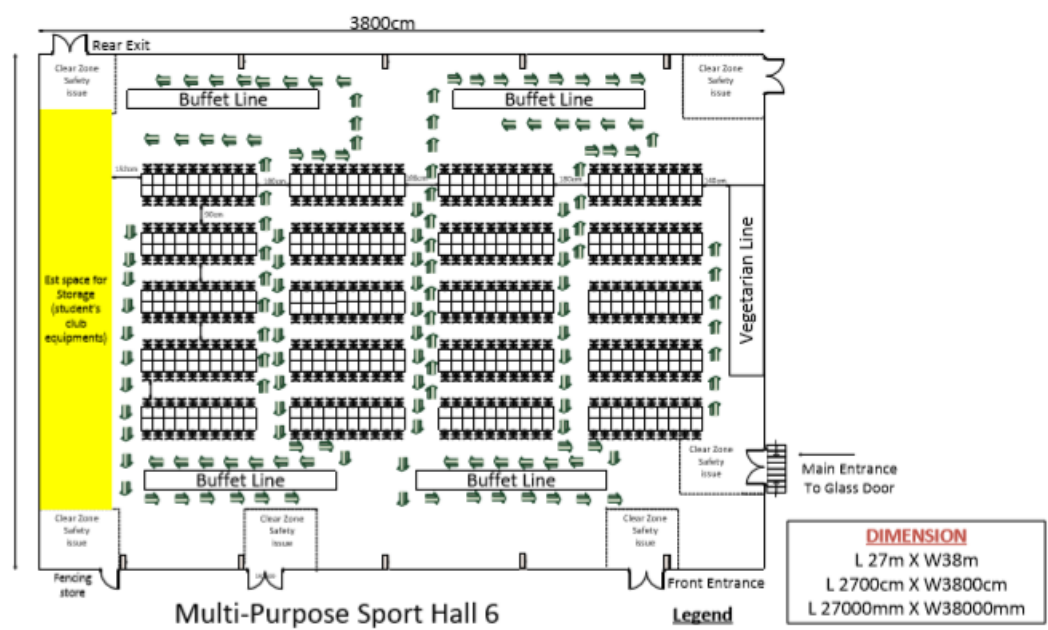

Total Tables & Chairs : 400

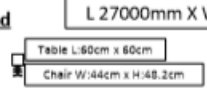

ADDENDUM 2: Regulation Changes:

There are three colours. **Green** is where we try to make the scientific aspects match what happens in reality (e.g., rewriting the appeals section, and merging judging procedures and competition rules). **Pink** covers all the changes related to Honourable Mentions. **Brown** is everything else.

[Square brackets are used to denote deletions]

S3.2: [Competition Rules and Judging Procedures] replaced by [the Contest Rules];

E3.1 Competition Tasks and confirm the award [ing of medals];

E3.4 [Adopt the Competition Procedures and the Judging Procedures of IOI'n]

A3.5 If there are fewer nominations than available positions then the remaining position(s) will be left empty, and will be filled during the following IOI for a term that is one year shorter. If the available positions have different term lengths, then the positions left empty will be those with the shortest terms.

E3.10 [Each] The member from each Host Country should be [represented by their] the [respective] Chair of their respective HSC.

E3.19.1

- Present these tasks and the associated [Competition Rules / Judging Procedures] Contest Rules to the GA for approval;
- Execute the [Competition Rules / Judging Procedures] Contest Rules;
- Support the GA with information that is needed for [the awarding of medals] allocating awards to the Contestants;

A3.19 If there is disagreement between the HSC and ISC regarding the preparation of the Contest Rules or the statements and/or test data for the Competition Tasks, then this disagreement will be resolved through a formal vote of the ISC (which includes a representative from HSC).

S5.3 [Competition Procedures and Judging Procedures, both] Contest Rules in English.

A5.3 • Competition: establishing a Host Scientific Committee, global description and preparation of Competition Tasks and associated judging model, equipment & software, conducting the Competition, technical support, [competition procedures] Contest Rules;

• Awards: [Judging Procedures], medals and Honourable Mentions;

The [Competition Procedures] Contest Rules contain information about: asking questions, reporting failures, testing data-files, printing, decision using private media (with or without software or data-files), decision about using private printed or written materials, visiting the refreshment rooms, [handing in]submitting solutions, and so on, during the Competition.

S5.7 [Competition Procedures; Judging Procedures] Contest Rules;

E5.4 [Adopt the Competition Procedures and the Judging Procedures.]

E5.5 Adopt the Contest Rules;

E 5.8 The second team will participate on an equal footing with all other teams, but will not be ranked in the final results used for the [awarding of medals] allocation of awards, and are not officially considered to be medallists or to receive Honourable Mentions;

- Any member of the second team with a score no less than the score necessary to achieve a [bronze medal] an Honourable Mention will receive a certificate which denotes their unofficial status and the rank of [medal which] the award that corresponds to their score.

[N5.6.2 The IC and GA have voted to waive the obligations of E5.6 for those Current and Future hosts at the time when this Explication was added to the Regulations (that is, at the time of IOI 2016).]

S5.10 Issue awarding certificates for [medal winning] contestants who win medals or Honourable Mentions;

[• Post official final results containing the final scores of the medal winning contestants;• Post a list of all Participants;]

- Produce a full result list containing the final scores of all contestants, as well as a list of all Participants, which [is] are made available to the OIOI and ISC, along with the data required to generate those scores;

E5.11 There will be an annual program to recognize individuals for their contribution to the activities of IOI,through Distinguished Service Awards.

Made a significant contribution to the activities and development of IOI, beyond the usual activities of a Delegation Leader, Deputy Leader or IOI Host;

N5.10 The full result list will, as a consequence, be published through the IOI Statistics website.

In S6.4 to S6,10, references to Competition Procedures and/or Judging Procedures were replaced with Contest Procedures.

S6.8 Delegation Leaders must be present for [at least the first half of the Competition] should be available on each Competition Day,...

. Tasks. The questions are to be answered by the HSC and ISC,

S6.9 Evaluation is to be carried out [directly after] during the Competition, or as soon as possible after...

S6.10 If the Delegation Leader does not agree with the evaluation of [a task element] the tasks or other aspects of the Competition that affect their Contestants' scores, [the disagreements are to be submitted]they should submit an appeal according to the [Judging Procedures] Contest Rules.

A6.9 Evaluation: • The Organizing Committee executes the evaluation of the Competition Tasks according to the [Judging Procedures] Contest Rules;

- The outcome of the evaluation of each task element is registered on Evaluation Forms;
- The Evaluation Forms of contestants are distributed to the contestants' Delegation Leader]
- The outcome of the evaluation of each task element is made available to the Contestants and, after the Competition, also their Delegation Leaders; [new]
- The evaluation data and the contestants' solutions [programs] are made available to the [contestants' Delegation Leader] Contestants and their Delegation Leaders after the Competition.

A6.10 DisagreementsAppeals:

- When a Delegation Leader has registered a disagreement, the Leader should be available for a consultation between a member of the HSC at a time which should be agreed when the disagreement is registered;
- The consultation may lead to a new allocation of points. If the Delegation Leader still does not agree with the evaluation, the disagreement, with possible further arguments from the Delegation Leader, will be discussed by the HSC. The HSC will make a final proposal of points;
- If this final proposal is not accepted by the Delegation Leader, the Delegation Leader can bring the controversy to the ISC;
- The ISC will make a final decision after presentations by the Chair of the HSC and the Delegation Leader;]
- When a Delegation Leader submits an appeal, the HSC and ISC will investigate. The ISC will then decide upon a resolution, which may lead to a new allocation of points;

The ISC will [make public all decisions] present to the GA a summary of all appeals and resolutions. Where possible, this summary will avoid identifying the Countries involved. If [three or more contestants have made the same appeal] similar appeals have been submitted on behalf of three or more contestants, the ISC's [decision] resolutions must be ratified by the G.A.

S6.11 In addition, about 20% of all contestants will be acknowledged with Honourable Mentions, but will not receive medals.

E6.11 For those contestants who do not receive medals, the score necessary to achieve an Honourable Mention is the largest score such that at least 70% of all contestants receive either a medal or an Honourable Mention.

If, before the end of the GA meeting in which the awards are confirmed, it is discovered that one or more Contestants fails to meet the eligibility criteria of S2.5, then the number of contestants used to compute [medal] award boundaries will be reduced accordingly.

E6.12 If a contestant is disqualified, they will still be counted for the purpose of computing [medal] boundaries for awards, as described by E6.11.

E6.14 The [medal] award boundaries, as described by E6.11, are determined using only those Contestants who are competing on-site in the Host Country. The official archives and website of the IOI will also include the remote Competitors, with awards based on the [medal] boundaries that were determined on-site.

S7.4 [Experimental] Regulation [s (or)changes[)] may be implemented more quickly, without the full procedure of S7.3, provided there is IC approval. The GA requires at least one months notification. The GA must ratify these changes in the first GA meeting of IOI'n, and if ratified then the changes become binding immediately after this vote.